

Series IKI-55

Feeder Control Units for Distribution Network Stations

The **IKI-55** Feeder Control Unit can be used in load switchgear for directional fault detection, load flow measurement, and control of load and ground switches. Likewise, a number of automation and monitoring functions are available with the **IKI-55**. The **IKI-55** is network-capable in its basic version and can communicate with the control station and other remote stations via various communication protocols. It can also be used as a Modbus master. The **IKI-55 M** is a Modbus-only variant.



Properties

The IKI-55 is designed for the connection of small-signal current transformers according to IEC 61869-10 as well as small-signal voltage transformers according to IEC 61869-11. In conjunction with a **sensor adapter**, conventional conversion transformers for current measurement as well as capacitive and precision dividers can be connected.

Fault detection

- Directional short-circuit detection
- Directional ground short-circuit detection
- Directional ground fault detection with static and transient fault detection
- Ground fault detection via pulse locating
- Suitable for all neutral point treatments
- No summing transformer required
- Fault recording with export as Comtrade file

Early fault detection

- Detection of transient faults (Intermittent ground faults)
- In conjunction with a CAPDIS- S2_55 (R5): Detection of partial discharges and their frequency and trend

Load flow measurement

- Voltages, currents, powers, frequencies, cos phi
- Momentary and average values
- Cross calibration (With additional adapter)
- Phase comparison function for voltages (With additional adapter)

Comprehensive control and monitoring functions

- Control of motor controllers for switching load and ground switches
- Free programmable logic functions
- Automatic Transfer Switch (ATS)
- Limit value monitoring

Simple operation of the unit

- Additional LEDs to indicate the fault direction
- Self-explanatory operation via direction keys

Extended safety features

- User roles safety concept, password protected
- Remote firmware update via REST interface (deactivable)
- USB interface deactivable

Communication protocols (Except IKI-50 M)

- IEC 60870-5-104 for communication with control center
- MQTT, REST for communication with databases or management systems
- Modbus RTU (Master)

Communication protocols version IKI-55 M

- Modbus RTU (Slave)

PT100 input for temperature compensation of sensors (Versions IKI-50 T..)

- E.g. for Siemens SIBushing sensors

Power-Quality (Versions IKI-50 PQ..)

- Monitoring of voltage quality according DIN EN 50160 (Frequency, voltage dips, voltage swells, voltage interruptions, rapid voltage changes)

Technical Data

Device data

Article number	IKI-55
Quantity unit	Piece
Product designation	Grid Controller IKI-55
Number of feeders	1
Parameterization software	KriesConfig

Series IKI-55

Feeder Control Units for Distribution Network Stations

Device data

Configuration	Via HMI and display (limited), Via software Kries-Config (download at kries.com)
---------------	--

Operating elements and display

Front display	LC-Display and LEDs
Direction keys	1 - 4 for navigation in menu
Red LED (1)	Error event detected
Yellow LED (2)	Device warnings
Green LED (3)	Status message device state
Yellow LED (4)	Fault detected in the direction of the busbar
Red LED (5)	Error event detected in the direction of the cable

Dimensions and installation instructions

Case height x width x depth	48 x 96 x 110 mm
Cutout height x width	45 x 92 mm
Norm cutout dimensions	DIN IEC 61554:2002-08
Installation type	Panel mounting

Operating conditions

Operating temperature	-40°C ... 70°C
Storage temperature	-40°C ... 80°C
Protection class front side	IP54
Protection class	IP40 / Front IP54
System frequency	50 Hz / 60 Hz (selectable)

Fault detection and failure forecast

Fault detection	Individually selectable, any combinations possible
Star point types	Short-term low-ohmic terminated neutral, Low-ohmic terminated neutral, Inductive terminated neutral, Isolated neutral
Short circuit detection I>>	✓
Directional short-circuit detection I>>	✓
Threshold current short-circuit detection I>>	50 A – 1,000 A
Threshold time short-circuit detection I>>	40 ms – 5 s
Earth short-circuit detection Ie>>	✓
Directional earth short-circuit detection Ie>>	✓
Threshold current earth short-circuit detection Ie>>	10 A – 1,000 A



Kries Energietechnik GmbH & Co. KG

Sandwiesenstr. 19 | D-71334 Waiblingen

kries.com | sales.kries@te.com | (+)49-7151-7074-860

22.08.24

Page 3/9

Series IKI-55

Feeder Control Units for Distribution Network Stations

Fault detection and failure forecast

Threshold time earth short-circuit detection $I_{e>>}$	40 ms – 5 s
Directional static earth fault detection $I_{e>}$;	✓
Threshold current static earth fault detection $I_{e>}$	2 A – 30 A
Threshold time static earth fault detection $I_{e>}$	200 ms – 2 s
Directional transient earth fault detection $I_{e>}$	✓
Threshold current transient earth fault detection $3I_0$	1 A – 1,000 A
Threshold voltage transient earth fault detection $3U_0$	0.1 kV – 100 kV
Earth fault detection via pulse locating	✓
Pulse length of pulse locating	symmetrical / asymmetrical
Transient fault detection $I_{le>}$	✓
TE trend monitoring	<ul style="list-style-type: none">• In conjunction with CAPDIS-S2_55 (R5)• Indication on the display, transmission via Modbus-RTU• Partial discharge trend via frequency distribution; integration over 24 h, trend over 72 h
Fault reset	Auto, Manually on the device, After time (1 h ... 8 h, configurable)
Reset setting	Time: 1 - 1 h; manual, auto
Event log	20 events
Fault recorder	✓
Fault record - formats	Comtrade
Fault record - number	20
Fault record - recording duration	2,5 s at 50 Hz 2,09 s at 60 Hz
Fault record - Frequency	6,4 kHz at 50 Hz 7,68kHz at 60 Hz
Fault record - Pretrigger	0,31 s at 50 Hz 0,258 s at 60 Hz
Earth fault transient detection	✓
Directional earth short-circuit detection	✓

Interfaces and transmission protocols

USB interface	Mini-USB
Transmission protocols	Version IKI-55 M: Modbus-RTU (Slave) All other versions: MQTT, REST, IEC 60870-5-104, Modbus-RTU
Modbus-RTU	✓
Modbus RTU Master	✓
Modbus-RTU Slave	✓
Modbus transmission rates [kBd]	9600, 19200, 38400, 57600, 115200

Series IKI-55

Feeder Control Units for Distribution Network Stations

Interfaces and transmission protocols

MQTT	✓
REST API	✓
IEC 60870-5-104 Slave	✓
Encryption of communication (LAN)	TLS
LAN connection	✓
Slave test	✓
Digital Inputs	6
Digital inputs - connections	Push-In, Connection of solid and stranded conductors: 0.08 to 0.5 mm ² Connection of stranded conductors with ferrule: 0.25 to 0.34 mm ²
Digital inputs - switching thresholds	ON > 19 VDC / OFF < 10 VDC
Digital inputs - voltage ranges	24 DC to 60 VDC
Digital inputs - current consumption	Max. 6 mA
Digital Outputs	6
Digital outputs for 1.5 pole switching	2
Digital outputs - connections	Push-In, Connection of solid and stranded conductors: 0.08 to 0.5 mm ² Connection of stranded conductors with ferrule: 0.25 to 0.34 mm ²
Digital outputs - variants	Floating
Digital outputs - switching capacity	1 A at 30 VDC
Digital outputs - dielectric strength	Max. 80V
Digital IOs configurable	Yes
Switching functions feeder control unit	Switching of up to two load switches 1.5-pole switching
Voltage input Input impedance	2 MOhm, 50 pF
Voltage input Input range	0,4 V – 4,1 V
Voltage input measurement accuracy	1%
Voltage input transformation ratio	10000:1 (settable)
Voltage input standard	IEC 61869-11
Current input Version	Rogowski current sensor
Current input Input impedance	10 MOhm, 50 pF
Current input Measuring range	0,1 A up to 2000 A
Current input Measuring accuracy	1%, +- 0.5 A
Current input Ratio	50 A / 22,5 mV (50Hz) (settable)
Current input standard	IEC 61869-10
PT100 input for temperature compensation of sensors	✓
Voltage inputs	1 (With additional adapter 2: 2x LRM/CAPDIS or 1x LRM/CADPIS + 1x precision 3.25V)

Series IKI-55

Feeder Control Units for Distribution Network Stations

Measurement values and functions

Voltage measurement	✓
Phase-to-ground voltages	✓
Phase to phase voltages	✓
Precision voltage measurement	Yes
Current measurement	✓
Active power	✓
Reactive power	✓
Apparent power	✓
Rotary field detection	✓
Frequency measurement	✓
Limit value monitoring	Parameterizable
Logic functions programmable	A total of 32 logic rules can be programmed.

Power supply

Auxiliary power supply	24 VDC/AC +/-20%
Power input - power consumption	0.5 A
Power supply input - connections	Connection of solid and stranded conductors: 0.2 to 2.5 mm ² / Connection of stranded conductors with ferrule: 0.25 to 1.5 mm ² / Connection of stranded conductors with ferrule without plastic collar: up to 2.5 mm ²
CT-supplied	-

Current transformers in connection with IKI small signal / sensor adapter

Article number	Product designation
2512106_H001	IKI-LUM_d92 Split-Core Transducer with cable tie (set) Ø 92mm
2512106_H003	IKI-LUM_d92 Split-Core Transducer for C-Cone-Bushings (set) Ø 92mm
2512106_H004	IKI-LUM_d92 Split-Core Transducer for SIEMENS-Bushings (set) Ø 92mm

Connecting cables CTs

Article number	Product designation
3503118_S	Connecting cable set pluggable Length = 3,0m



Kries Energietechnik GmbH & Co. KG

Sandwiesenstr. 19 | D-71334 Waiblingen

kries.com | sales.kries@te.com | (+)49-7151-7074-860

22.08.24

Page 6/9

Series IKI-55

Feeder Control Units for Distribution Network Stations

Article number	Product designation
3503135_S	Connecting cable set pluggable Length = 5,0m
3503135_S999	Connecting cable set pluggable Lengths on request

Accessories

Article number	Product designation
2502466_H001	Small-Signal Sensor-Adapter Interfaces: IKI-LUM, U-LRM, U-LRM
2502466_H002	Small-Signal Sensor-Adapter Interfaces: IKI-LUM, U-LRM, U-DIV
2502403	CT-Adapter Interfaces: Current x/1A, Voltage x/100V

Comparison of products

	IKI-55 2502400_H003	IKI-55 M 2502400_H001	IKI-55 PQ 2502400_H004	IKI-55 T 2502400_H103
Level of digitalisation	2	2	2	2
Short circuit detection I>>	✓	✓	✓	✓
Directional short-circuit detection I>>	✓	✓	✓	✓
Earth short-circuit detection Ie>>	✓	✓	✓	✓
Directional earth short-circuit detection Ie>>	✓	✓	✓	✓
Earth fault transient detection	✓	✓	✓	✓
Pulsation detection	✓	✓	✓	✓
Directional static earth fault detection Ie>;	✓	✓	✓	✓
Slave test	✓	✓	✓	✓
Modbus-RTU	✓	✓	✓	✓
Modbus RTU Master	✓	-	✓	✓
Modbus-RTU Slave	✓	✓	✓	✓
IEC 60870-5-104 Slave	✓	-	✓	✓
MQTT	✓	-	✓	✓
REST API	✓	-	✓	✓
LAN connection	✓	-	✓	✓

Series IKI-55

Feeder Control Units for Distribution Network Stations

	IKI-55 2502400_H003	IKI-55 M 2502400_H001	IKI-55 PQ 2502400_H004	IKI-55 T 2502400_H103
Encryption of communication (LAN)	TLS		TLS	TLS
CT-supplied	-	-	-	-
Auxiliary power supply	24 VDC/AC +/-20%	24 VDC/AC +/-20%	24 VDC/AC +/-20%	24 VDC/AC +/-20%
USB interface	Mini-USB	Mini-USB	Mini-USB	Mini-USB
PT100 input for temperature compensation of sensors	-	-	-	✓
Digital Inputs	6	6	6	6
Digital Outputs	6	6	6	6
Digital IOs configurable	Yes	Yes	Yes	Yes
Switching functions feeder control unit	Switching of up to two load switches 1.5-pole switching	Switching of up to two load switches 1.5-pole switching	Switching of up to two load switches 1.5-pole switching	Switching of up to two load switches 1.5-pole switching
Digital outputs for 1.5 pole switching	2	2	2	2
Voltage inputs	1 (With additional adapter 2: 2x LRM/CAPDIS or 1x LRM/CADPIS + 1x precision 3.25V)	1 (With additional adapter 2: 2x LRM/CAPDIS or 1x LRM/CADPIS + 1x precision 3.25V)	1 (With additional adapter 2: 2x LRM/CAPDIS or 1x LRM/CADPIS + 1x precision 3.25V)	1 (With additional adapter 2: 2x LRM/CAPDIS or 1x LRM/CADPIS + 1x precision 3.25V)
Voltage measurement	✓	✓	✓	✓
Precision voltage measurement	Yes	Yes	Yes	Yes
Power Quality according to DIN EN 50160			Frequency IEC 61000-4-30 cl. 5.1 Voltage dips IEC 61000-4-30 cl. 5.4 Voltage swells IEC 61000-4-30 cl. 5.4 Voltage interruptions IEC 61000-4-30 cl. 5.5 Rapid voltage changes IEC 61000-4-30 cl. 5.11	
Current measurement	✓	✓	✓	✓
Logic functions programmable	A total of 32 logic rules can be programmed.	A total of 32 logic rules can be programmed.	A total of 32 logic rules can be programmed.	A total of 32 logic rules can be programmed.
Balanced core CT optional	-	-	-	-
Compatible CTs	IKI-LUM_d92 Split-Core Transducer with cable tie (set) Ø 92mm (2512106_H001) IKI-LUM_d92 Split-Core Transducer for C-Cone-Bushings (set) Ø 92mm (2512106_H003) IKI-LUM_d92 Split-Core Transducer for SIEMENS-Bushings (set) Ø 92mm (2512106_H004)	IKI-LUM_d92 Split-Core Transducer with cable tie (set) Ø 92mm (2512106_H001) IKI-LUM_d92 Split-Core Transducer for C-Cone-Bushings (set) Ø 92mm (2512106_H003) IKI-LUM_d92 Split-Core Transducer for SIEMENS-Bushings (set) Ø 92mm (2512106_H004)	IKI-LUM_d92 Split-Core Transducer with cable tie (set) Ø 92mm (2512106_H001) IKI-LUM_d92 Split-Core Transducer for C-Cone-Bushings (set) Ø 92mm (2512106_H003) IKI-LUM_d92 Split-Core Transducer for SIEMENS-Bushings (set) Ø 92mm (2512106_H004)	IKI-LUM_d92 Split-Core Transducer with cable tie (set) Ø 92mm (2512106_H001) IKI-LUM_d92 Split-Core Transducer for C-Cone-Bushings (set) Ø 92mm (2512106_H003) IKI-LUM_d92 Split-Core Transducer for SIEMENS-Bushings (set) Ø 92mm (2512106_H004)

Series IKI-55

Feeder Control Units for Distribution Network Stations

Application examples

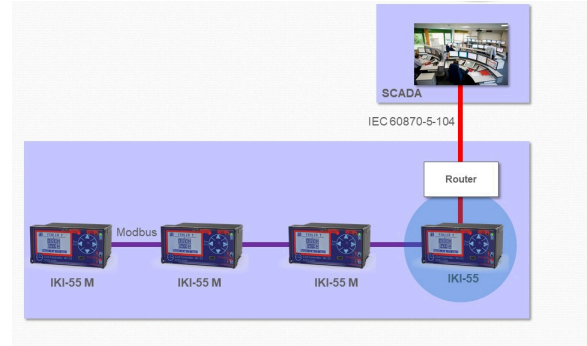
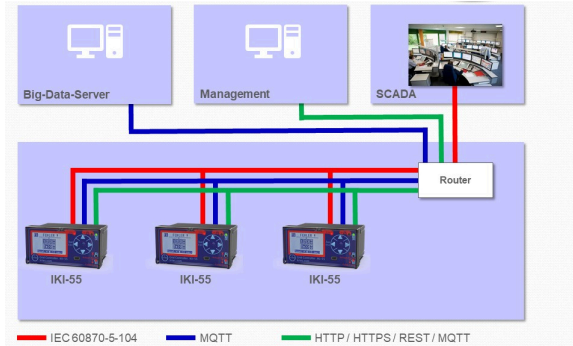

Block diagram (Version IKI-55)

